



Research article

Performance evaluation of the inside intersection median-turn lane markings on the mobility and safety performance of signalized intersections in the Philippines and Japan

John Jowhell Villegas^{a,d,*}, Wael K.M. Alhajyaseen^b, Hideki Nakamura^a, Azusa Goto^c

^a Graduate School of Environmental Studies, Nagoya University, Furo-cho, Chikusa-ku, Nagoya 464-8603, Japan

^b Qatar Transportation and Traffic Safety Center, Qatar University, Doha, P.O. Box 2713, Qatar

^c National Institute for Land and Infrastructure Management, Ministry of Land, Infrastructure, Transport and Tourism, Tsukuba 305-0804, Japan

^d Engineer III Traffic Engineering Division, Department of Public Works and Highways DPWH Head Office, Bonifacio Drive, Port Area, Manila 1018, Philippines



ARTICLE INFO

Article history:

Received 21 August 2017

Received in revised form 7 December 2017

Accepted 12 December 2017

Available online 15 December 2017

Keywords:

Median turning lane
Pavement markings
Saturation flow rate
Safety
Signalized intersection

ABSTRACT

Signalized intersections are one of the key elements that play a vital role at road networks. The efficiency and safety levels of intersections can affect the operational performance of the whole system. In general, turning traffic, especially median-turning, has always been considered as the most problematic movement in the operation of intersections. This becomes more critical with high turning demand where exclusive turning lanes (single or double) can be assigned to provide larger capacities for these movements and to reduce conflicts with through traffic. However, improper treatment of median-turn lanes could create cross-maneuvering behavior which may limit the expected increase in capacity and create safety issues. Median-turning lane markings are commonly provided at intersections in Japan to guide drivers while turning which is expected to reduce the conflicts among turning traffic. Meanwhile, in the Philippines, exclusive median-turn lanes are installed at intersections without proper treatment which may contribute to the low mobility and safety levels. Therefore, this study evaluated the impact of inside intersection lane markings on the operation of median-turn lanes in terms of mobility and safety. The vehicle maneuver, speed and interactions between the turning traffic were utilized as essential components for the assessment. The empirical analysis shows that conflicting trajectories were present on double turn lanes without median-turn lane markings in the Philippines, which resulted to serious conflicts among the turning vehicles and negatively influenced the turning speed and saturation flow rate of the turn lanes. On the other hand, the turn lane markings in Japan, provided a positive impact to mobility and safety of the turning lanes. Moreover, it was also found that the geometric characteristics and traffic signal phasing scheme highly affects the capacity and safety condition of signalized intersections.

© 2017 International Association of Traffic and Safety Sciences. Production and hosting by Elsevier Ltd. This is an open access article under the CC BY-NC-ND license (<http://creativecommons.org/licenses/by-nc-nd/4.0/>).

1. Introduction

Signalized intersections are the most common bottlenecks in road networks especially within urban areas. They are common spaces being shared by several roads where vehicles from different approaches are given the right of way through signal indication to avoid conflicts between them. If improperly and inefficiently managed it could result in congestion and safety issues. At signalized intersections, managing turning traffic is one of the main challenges especially at high turning

demand. In such cases, median-turn movements, right-turn in countries with left-hand driving system and left-turn in countries with right-hand driving system, are being provided with exclusive turn lanes to accommodate their demand and to reduce the conflicts with through traffic. However, the departure flow rate of vehicles on turn lanes is relatively lower as compared to the through movement due to the geometric impact of intersection which yields to lower capacities. At high median-turn demand, double exclusive lanes are provided to increase the capacity of the median-turning lane group. According to the technical assistance report by Brich [1] for the Virginia Transportation Research Council (VTRC), double exclusive median-turn lanes has a potential capability of increasing the capacity of a single turn lane up to 180%. This positive impact can only be realized with appropriate utilization of median-turn lane markings inside intersections to guide vehicles while turning in the inside and outside double median-turn lanes.

* Corresponding author.

E-mail addresses: villegas.john_jowhell@dpwh.gov.ph (J.J. Villegas), wjaseen@qu.edu.qa (W.K.M. Alhajyaseen), nakamura@genv.nagoya-u.ac.jp (H. Nakamura), goto-a92uj@mlit.go.jp (A. Goto).

Peer review under responsibility of International Association of Traffic and Safety Sciences.

In Japan (left hand driving system), most signalized intersections are equipped with median-turn lane markings [2], usually known as “right-turn lane markings” (Fig. 1(b)), to delineate the path of vehicles while turning to limit the degrees of freedom of drivers which contribute to the minimization of lane changing and the reduction of conflicts between turning traffic. Median-turn lane markings have also been utilized in many countries such as Germany, USA, Qatar, and United Arab Emirates. In the United States of America, where it is known as “positive guidance pavement markings or skip lines”, several studies [1] suggested that median-turn lane markings are effective in improving double exclusive turn lanes operation. In the Philippines, the Road Signs and Pavement Markings Manual 2012 [3] suggests similar pavement markings for median-turn lanes, however, it is not being implemented in reality. Only “Yellow-Box markings” are being implemented inside urban signalized intersections (Fig. 1(a)), which is only intended to inform drivers that it is prohibited to stop within the area of the intersection at any time. It can be presumed that the absence of proper median-turn lane markings at signalized intersections especially in the case of double exclusive median-turn lanes, could be one of the factors that contributes to the severely increasing traffic congestion and road traffic crash incidents within the capital of the Philippines, Metropolitan Manila.

According to the JICA Technical Report in 2014 [4], Philippines is losing approximately 47.7 million US\$ per day due to this congestion issues in Metropolitan Manila alone. In general, the report attributed the severe congestion to several reasons: (i) long cycle time of signalized intersections; (ii) right-turn on red is allowed even without yielding to traffic with priority, and; (iii) absence of signal coordination to maximize throughput. Furthermore, another important reason is the commonly adopted 4-phase approach-based signal plan regardless of the relative demand of different traffic movements. Moreover, this expanding congestion problem could be directly correlated to the increasing road crash incidents within the Metropolitan Manila. The Accident Reporting and Analysis System of the Metropolitan Manila Development Authority (MMDA) reported an increase of 79% in the number of crashes from 2006 to 2016 [5]. Many studies such as Persaud [6], Abdel-Aty [7] and the State Highway Administration Research Report (MD-030SP 208B46) of the Maryland Department of Transportation [8], concluded that road crash frequency and traffic volume at congested roadways are highly correlated. This severely increasing mobility and safety issues in Manila are drawing attention to the traffic engineers to develop or adapt techniques that could help on alleviating traffic problems at signalized intersections. It can be hypothetically assumed that the absence of proper median-turn lane markings at signalized intersections with double exclusive lanes can generate conflicts between turning traffic that may deter the potential positive impact of exclusive turn lanes to the capacity of intersections. However, the extent of this hypothesized negative impact is not yet known.

The objective of this paper is to investigate the impacts of the median-turn lane markings on the efficiency and safety performance of double median-turn lanes in terms of mobility and safety. This paper focuses on the assessment of urban signalized intersections in Manila, Philippines, equipped with single and double exclusive median-turn lanes without turn lane markings, and compares them to urban signalized intersections in Japan with and without turn lane markings. Saturation flow rates, turning maneuvers including speed and paths, and conflicts between turning traffic are empirically observed and analyzed. Lastly, this paper ends with conclusion and future work.

2. Literature review

Commonly, previous studies measured the mobility performance of the median-turn lanes in terms of saturation flow rate (SFR). Brich [1] examined double turn lanes equipped with median-turn lane markings in Virginia. He concluded that the provision of pavement markings enables the turning vehicles to traverse the intersection safely and efficiently. In his study, he cited the work of O’Leary [9] who conducted questionnaire survey and found out that 70% of the respondents indicated that median-turn lane markings were very helpful for the drivers. A similar study was conducted by Wei and Guo [10] in China, they extracted and analyzed the characteristics of trajectories, speed and flow of turning vehicle. They concluded that median-turn lane markings have a potential in controlling vehicles’ turning process that can result in the improvement of traffic efficiency and reduction of traffic conflict.

In addition, several studies suggested that mobility performance of median-turn lanes are also highly affected by intersection geometric characteristics. Fitzpatrick and Park [11] analyzed data from 26 signalized intersections with double median-turn lanes in the US and determined the effects of geometric characteristics on double median-turn lane operations, as measured by SFR. The study concluded that inside and outside lane SFRs are almost equal and the number of available receiving lanes at the exit approach affects the SFR, with one additional receiving lane could potentially increase the SFR by 50 pcphgpl (passenger cars per hour of green per lane). Also, the study found out that the receiving lane width affects the SFR where wide lanes have potential to increase the flow rate. In another study, fifteen intersections with triple left-turn lanes were examined by Sando and Moses [12]. They investigated the influence of geometric characteristics to the operation of triple left-turn lanes and found that left-turn lanes on downgrades and with turn angle < 90° highly contribute to high saturation flow rate. They also concluded that multiple left-turn lanes located at one-way streets and on curved approaches have low SFR.

Traffic safety studies in particular to median-turn lane operation have been conducted by various researchers. Sobhani et al. [13] in Melbourne, Australia, analyzed traffic safety behavior of median-turn lanes

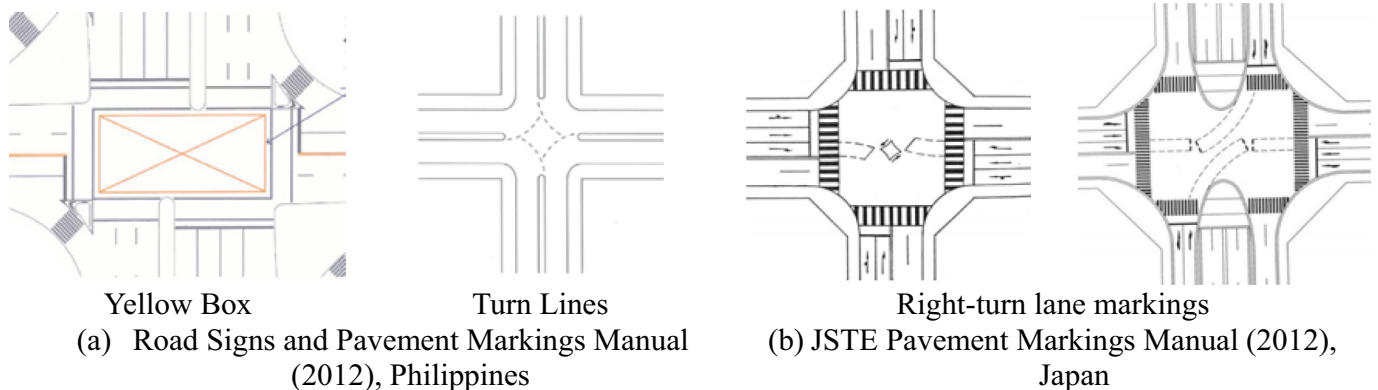

Fig. 1. Median-turn lane markings according to design manuals in the Philippines and Japan.

at signalized intersections. They stated in the study that road crash related to median turning movements is one of the major crash type taking place at intersections. In particular, they found out that different turning trajectories taken by the drivers influence the traffic conflict or risk related to median turn movements. A study conducted by Wang and Abdel-Aty [14] classified nine patterns of median-turn crashes based on the different approach maneuvers by studying over 6-year period of road crash data in Florida, USA. One of these patterns is the conflict between two left-turning vehicles on the same approach. Through the review of the road crash incidents database, they found out that majority of the crashes that occur in this crash pattern are rear-end and side-swipe collisions comprising 28% and 27.4%, respectively. In parallel, according to the road crash incidents based on the database of the MMDA in the Philippines (2016), side swipe collision and rear-end collision at intersections are the highest road crash type occurred from 2005 to 2016 with 35% and 20% of the total road crash incidents at intersections [5].

Laureshyn et al. [15] evaluated traffic safety of median-turn lanes based on micro-level behavioral data. Surrogate safety measures were utilized to analyze the traffic conflict and its accompanying risk severity. In the study, Time-To-Collision (TTC) and Post-Encroachment Time (PET) were used to microscopically describe the safety condition of an encounter between two road users who are simultaneously arriving at a conflict point. They emphasized that collision combination or the several possible collisions of different elements of a vehicle (*i.e. corner to corner, corner to side*) are an important consideration. The combination with the shortest time to conflict has the highest potential in leading to collision. In general, they conducted microscopic behavioral analysis to describe the trajectory, turning speed and time-based interaction between turning vehicles before and after they pass the conflict point and what evasive action was taken by one of the road users to avoid the collision.

Based on these literatures, it can be hypothetically assumed that the absence of median-turn lane markings at the subject intersection in the Philippines might result to conflicting trajectories that might lower the mobility performance and increase the risk of traffic conflict between the inside and outside lane turning vehicles. In addition, after reviewing the previous studies, it was realized that there is no existing study which analyzed the impacts of the median-turn lane markings in the operation of intersections in terms of mobility and safety simultaneously while relating to the trajectory characteristics of the subject turning vehicles.

3. Methodology

Fig. 2 demonstrates the evaluation process adopted in this study. Mainly, efficiency and safety performance were assessed in relation to the trajectory characteristics of the median-turning vehicles. The efficiency of the subject median-turn lanes was evaluated through SFR and turning speed. Furthermore, the impact of observed turning trajectories on the efficiency and safety performance of turn lanes were evaluated.

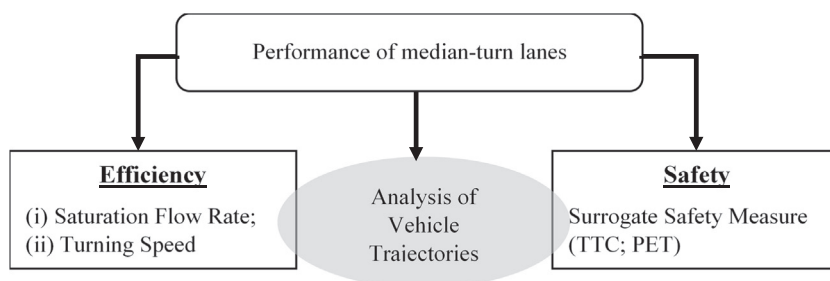

Fig. 2. Flowchart of the median-turn lane performance assessment.

The conflict severity of the interactions between vehicles in the inside and outside lanes were assessed and quantified. As shown in Fig. 3, observed conflicts were categorized into three main conflict encounters such as: (i) Non-Crossing Encounter; (ii) Crossing Encounter, and; (iii) Collision Encounter. Surrogate safety measures such as Post-Encroachment Time (PET) and Time-To-Collision (TTC) were used to measure the severity of conflict. Non-crossing encounter are the encounters where the paths of the inside and outside lane vehicle did not cross which eliminates the tendency of a collision during the turning process.

In cases where paths overlapped, potential conflict point between the two turning vehicles was evaluated. In this paper, conflict point is defined as the point where the trajectories of the two subject median-turning vehicles cross and might collide along the turning path. The trajectories of the leading and following turning vehicles were observed on the rear corner and front corner of the vehicles, respectively. The trajectory, turning speed, the expected arrival time of the subject turning vehicles on the conflict point and the evasive action taken by either of the two road users to avoid collision were analyzed and described through a micro-level behavioral analysis. Two possible turning conflict scenarios were assessed. First is when the leading vehicle (veh_i), either in the inside or outside lane, maintained its lead in terms of the arrival time at the conflict point throughout the turn from the stop line up to the conflict point. This scenario is called Crossing Encounter in which the paths of the turning vehicles will cross each other with a potential conflict measured using Post-Encroachment Time (PET) and defined as the elapsed time between the rear corner of the leading vehicle (veh_i) leave the conflict point and the front corner of following vehicle (veh_{i+1}) arrived at the conflict point. In this encounter, a possible delay of the leading vehicle, measured as PET, to leave the conflict point might lead to a collision.

The second scenario is when there's a point of time during the turning process where the arrival times of both leading vehicle (veh_i) and the following vehicle (veh_{i+1}) are equal ($t_i = t_{i+1}$). This means that if both vehicles at that moment continued in their turning maneuver maintaining the same speed, a collision will occur. This estimated arrival time ($t_i = t_{i+1}$) is called Time-To-Collision (TTC). This scenario is named as Collision Encounter. In reality, one/both of the conflicting vehicles usually react by changing their speed to avoid the collision which will lead to a difference in time between the arrival of both vehicles at the conflict point (PET). In this scenario, TTC and PET are used in the assessment.

3.1. Data collection

Video surveys were performed at two signalized intersections in Japan and one signalized intersection in the Philippines as shown in Fig. 4 where the subject median-turn lane approaches as highlighted by arrows. The observation sites in Japan are Kamisara intersection located in Nagoya City and Jimbocho intersection in Chiyoda Ward, Tokyo while the subject intersection in the Philippines is the Makati Avenue–Ayala Avenue intersection located in the central business district (CBD) of Makati City. It is important to mention that Jimbocho intersection is utilized for the SFR estimation only, while trajectory and safety analysis was not possible because of the low angle of the video.

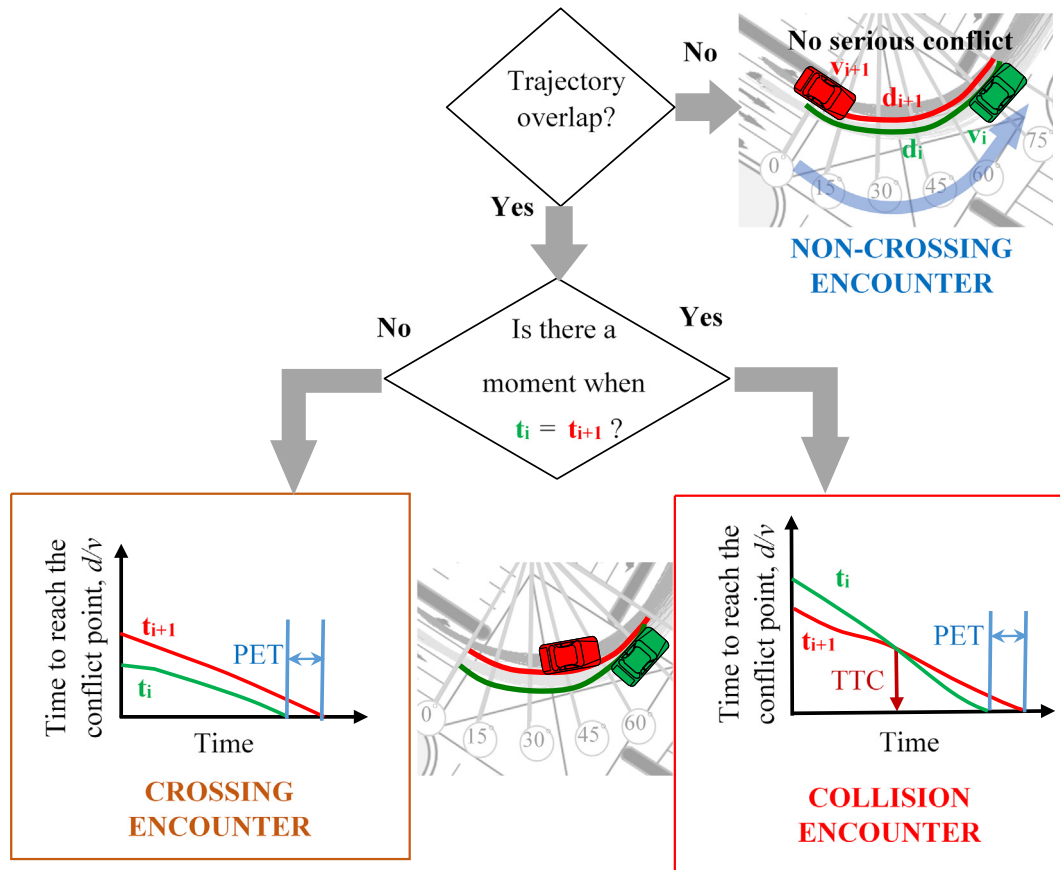

Fig. 3. Flowchart of traffic conflict analysis of double median-turn lanes.

The geometric characteristics of the subject intersections both in Japan and the Philippines are shown in Table 1 while the definitions of the geometric parameters are demonstrated in Fig. 5. All subject intersections are right angle with posted speed limit at all approaches of 60 kph. At Makati intersection, the subject approach is the North West (NWA) and it is operated with single exclusive median-turn lane in PM period due to the limited demand while two exclusive lanes are assigned for median turning vehicles in the AM period as observed during the survey. The inside lane width is 2.9 m while the outside lane has 3.0 m width. At Kamisara intersection, both inside and outside lanes of the East approach and the single turning lane at the West approach are 3.0 m wide.

As shown in Fig. 4 and Table 1, Makati intersection is a compact intersection while those in Japan are wide with large stop line step back distances. As shown in Table 1, the offset distance between the curb line and the location of the physical median island nosing at the entry approach (difference between y_4 and y_2) is 10.63 m in Kamisara intersection (Japan) while only 0.87 m at Makati intersection (Philippines). Similarly, at the exit approach, the offset distance between the curb line and the physical median island nosing (sum of x_2 and x_4) is 23.65 m in Kamisara intersection, while it is -0.45 m in Makati intersection which means that the nosing is within the intersection area.

As shown in Table 2, the traffic signal phasing scheme in Makati intersection is approach-based. However, Kamisara and Jimbocho intersections have 4-phase plan with exclusive median-turn protected phases. Relatively, the cycle length at Makati intersection is longer than in Kamisara intersection. Furthermore, right-turn on red (right-hand driving system) at Makati intersection is allowed which may cause conflicts with the subject median-turn lanes especially at high turning demand. It is important to mention that the traffic composition at Makati intersection is uniquely homogenous of mainly passenger cars since it is located within the CBD area; although it is common for the traffic composition in the Philippines to be heterogeneous.

Video Surveys at subject intersections are conducted in the dates and timings presented in Table 3. Vehicle trajectories were extracted from the collected video recordings using the video processing software “TrafficAnalyzer” [16].

3.2. Data processing

For the analysis of SFR, the headways between departing turning vehicles in the queue were extracted using TrafficAnalyzer and processed conforming to the Highway Capacity Manual 6th edition (2016) procedure [17]. The first four vehicles in the queue were dropped in the analysis to eliminate the impact of startup lost time and only passenger cars in the traffic stream were included.

Furthermore, only cycles with minimum of eight vehicles in queue were considered. Based on that, SFRs per lane of all the subject turn lanes were calculated and analyzed. In general, higher SFRs means higher efficiencies and capacities of the subject turn lanes.

Vehicle trajectory data per lane were extracted at 0.5 second interval. To analyze vehicle turning speeds, their distributions per lane were extracted at cross-sections located at 15° interval from the stop line of the entry approach of the median-turn lanes while the distributions of paths were extracted at 30° interval. The initial cross-section at 0° is the stop line of the entry approach of the median-turning vehicles and the last observation cross-section is at the extension of the stop line of the exit approach. At Kamisara intersection, 121 and 207 trajectories were extracted for the inside and outside turning lanes, respectively. Meanwhile, at Makati intersection 157 and 151 trajectories were extracted for the inside and outside turning lanes, respectively.

Using trajectory data, the encounters between the inside and outside lane turning vehicles were identified and classified following the procedure presented in Fig. 3. 111 and 90 encounters were observed at Makati and Kamisara intersections, respectively. These encounters

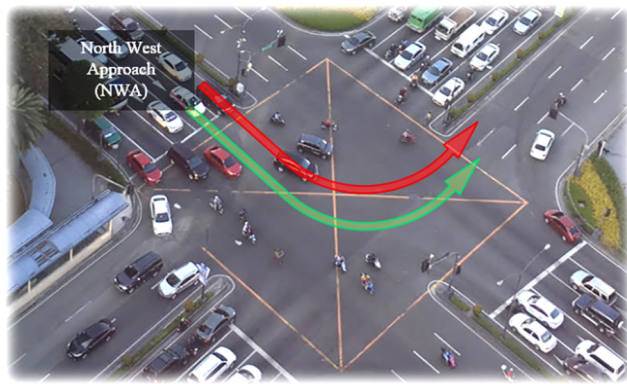

(a) North West Approach of Makati Intersection, Philippines

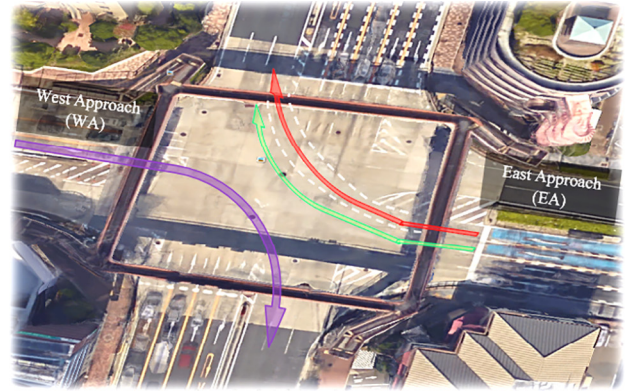

(b) East and West Approaches of Kamisara Intersection, Nagoya, Japan

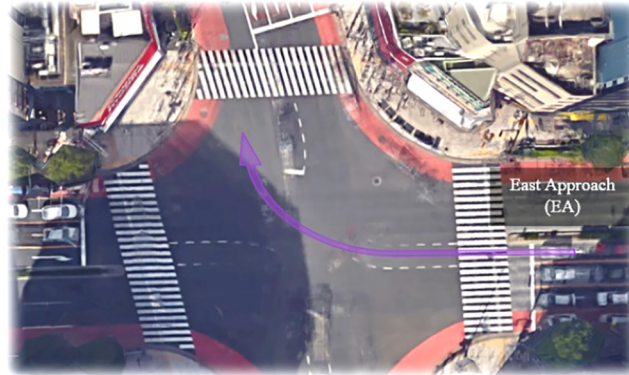

(c) East Approach of Jimbocho Intersection, Tokyo, Japan

Fig. 4. Subject intersections.

were categorized into Non-crossing, Crossing or Collision as defined in Fig. 3. Then the safety analysis was carried out for the Crossing and Collision encounters using PET and TTC, which were estimated using observed vehicle trajectories.

4. Results and discussion

4.1. SFR and turning speeds

Fig. 6 shows the distribution of the observed SFRs for single and double median-turn lanes at observation sites in the Philippines and Japan. It is clear that median-turn lanes in the Philippines have significantly

lower saturation flow rates compared to those in Japan for SMT and DMT. Fig. 6(a) shows that for SMT, WA of Kamisara intersection has higher SFR (significant at 95% confidence level) compared to that of the EA of Jimbocho intersection, which is attributed to the larger number of receiving lanes at the exit approach of the median-turning movement from the WA of Kamisara. This analysis indicates that for single median-turn lanes, the number of available receiving lanes at the exit approach has more significant impact on SFR than the provision of median-turn lane marking. On the other hand, both intersections in Japan have significantly higher SFRs for SMT compared to that of the NWA of Makati intersection in the Philippines, which has four receiving lanes at the exit approach and equipped with Yellow Box markings. This

Table 1
Geometric characteristics of the subject-turning lanes.

Parameters	NWA ^a /Makati	EA ^a & WA ^a /Kamisara		EA ^a /Jimbocho
	DMT and SMT ^a	DMT ^a (EA)	SMT ^a (WA)	SMT ^a
Turning lane marking	Without	With	Without	With
Intersection angle, α	87 deg.	88 deg.	87 deg.	74 deg.
Lane width (m)	Outside – 3.00 Inside lane – 2.90	Outside – 3.00 Inside – 3.00	3.15	2.80
No. of exit lanes	4	3	3	2
y_1	15.21	27.23	21.29	24.10
y_2	1.6	0.08	0.53	2.28
y_3	Not applicable	13.92	8.05	Not applicable
y_4	2.47	11.71	9.45	13.47
x_1	10.98	21.16	19.05	24.23
x_2	–4.26	6.23	–0.58	0.00
x_3	Not applicable	12.42	8.36	Not applicable
x_4	3.81	17.42	11.92	16.37

^a Note: NWA: North West approach, WA: West approach; and EA: East approach, DMT: double median-turn lanes; SMT: single median-turn lane.

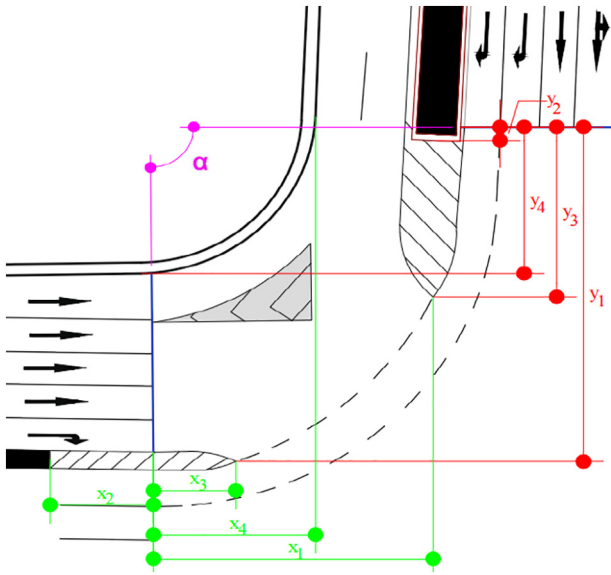

Fig. 5. Illustration of geometric characteristics related to median-turn lane layout.

low SFR can be attributed to the impact of the permitted right-turn on red at the opposite approach, which resulted to the reduction of the available receiving lanes at the exit approach. This impact of right-turn on red vehicles was only observed when NWA was operated with SMT. Furthermore, the compact layout of Makati intersection, where the hard nose of the median is extended to the border of the

Table 3
Details of video data at subject signalized intersections.

Intersection	Approach	Date of video survey	Time of the day
Makati	NW	November 30, 2016 (Wednesday)	3:30 pm to 5:00 pm
		December 1, 2016 (Thursday)	7:00 am to 11:00 am
Kamisara	E	July 25, 2013 (Thursday)	7:00 am to 9:00 am
	W		07:30 am to 9:00 am
Jimbocho	E	September 14, 2016 (Wednesday)	1:45 pm to 4:30 pm

intersection area, may also contribute by hindering vehicle turning speed and as a result reducing SFR.

For double median-turn lanes (DMT), Fig. 6(b) shows that observed SFRs for both turning lanes at the NWA of Makati intersection are significantly lower than those at the EA in Kamisara intersection. This is mainly attributed to the lane change behavior which becomes frequent due to the absence of turning lane markings at NWA of Kamisara intersection. This leaves drivers with high degree of freedom to select the exit lane and the desired turning maneuver, which increases the friction between turning vehicles and reduces their turning speed. This phenomenon yields to severe conflicts between turning vehicles in the double turning lanes and as a result reduction in discharge headway. Moreover, the compact layout of the intersections in the Philippines may also contributed to lower SFR especially for the inside lane as shown in Fig. 6(b).

To look deeper on the conflicts between turning vehicles at DMT, their observed trajectories were collected and analyzed. Fig. 7 shows observed vehicle paths at Kamisara and Makati intersections as well as the cross-sections at which the distribution of the speeds and paths were analyzed. By comparing Fig. 7(a) and (b), vehicle paths at the inside turning lane of Kamisara intersection are widely distributed compared

Table 2
Signal phase plans and timings.

	Signal phase	Length (sec)													Cycle length (sec)		
		ϕ_1			ϕ_2			ϕ_3			ϕ_4			ϕ_5			
		1	2	3	4	5	6	7	8	9	10	11	12	13			
Makati Intersection	South East	[Signal timing diagram for South East phase]													194		
	North West	[Signal timing diagram for North West phase]															
	North East	[Signal timing diagram for North East phase]															
	South West	[Signal timing diagram for South West phase]															
	Timings	70	3	16	2	40	2	1	24	2	1	30	2	1			
Kamisara Intersection	North & South	[Signal timing diagram for North & South phase]													150		
	East & West	[Signal timing diagram for East & West phase]															
	Timings	51	2	4	14	2	3	37	2	30	2	3					
	Movements (4 phases)	[Movement diagrams for Kamisara intersection]															
	Jimbocho Intersection	East & West	[Signal timing diagram for East & West phase]													150	
North & South		[Signal timing diagram for North & South phase]															
Timings		61	4	2	20	2	2	43	4	7	2	3					
Movements (4 phases)		[Movement diagrams for Jimbocho intersection]															

— Green — Protected RT — Amber — Red

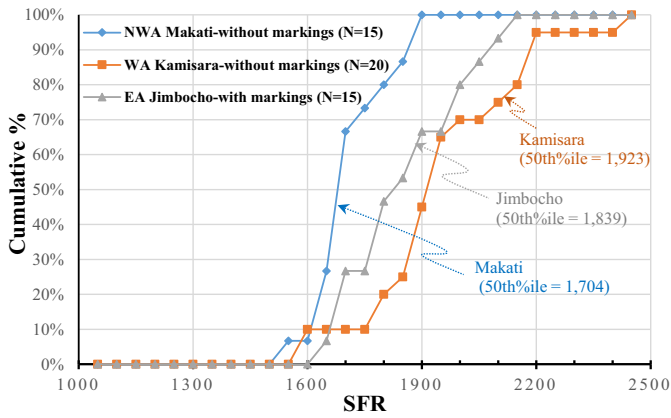

(a) Single Median-Turn Lane (SMT)

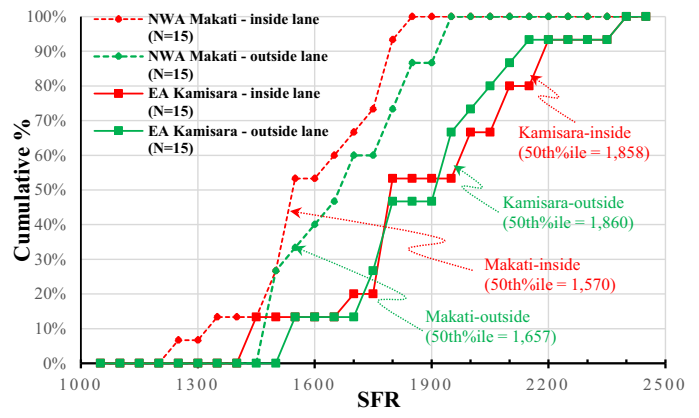

(b) Double Median-Turn Lane (DMT)

Fig. 6. Cumulative distribution of observed SFRs at subject median-turn lanes (pcphgpl).

to those at the inside lane of Makati intersection. This is attributed to the compact layout of Makati intersection, which limits the freedom of inside lane turning vehicles, whereas at Kamisara intersection, the offset distance of the median hard nose is 10.63 m which encouraged the inside lane turning vehicles to freely turn with a wide turning area. This is reflected in the significantly higher standard deviation of paths and

average speeds at the inside turning lane of the EA of Kamisara intersection as shown in Fig. 7(c) and (d), respectively.

In contrary, Fig. 7(c) shows an opposite tendency for the outside turning lanes between Kamisara and Makati intersections compared to inside ones. This can be attributed to the signal phasing plans at both intersections. The phasing scheme at Kamisara intersection is a

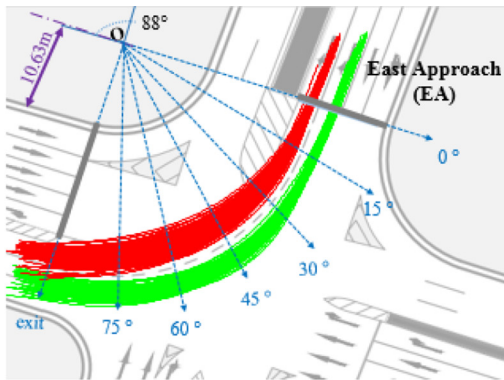

(a) EA of Kamisara Intersection, Japan

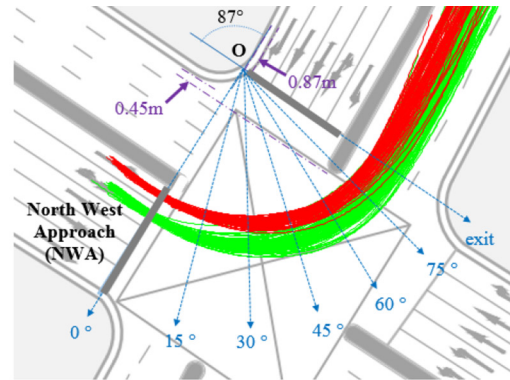

(b) NWA of Makati Intersection, Philippines

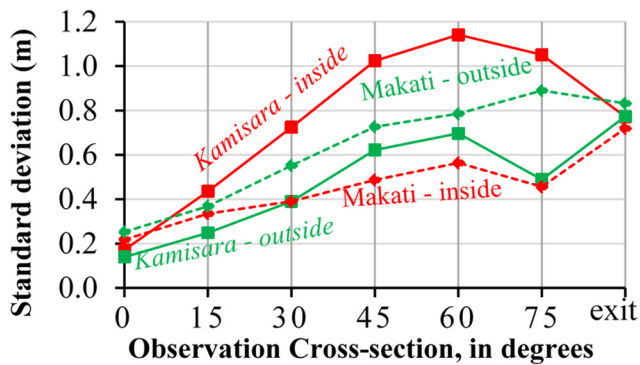

LEGEND:

EA Kamisara-inside lane (N=121)
EA Kamisara-outside lane (N=207)

(c) Standard deviation of vehicle trajectories at different cross-sections

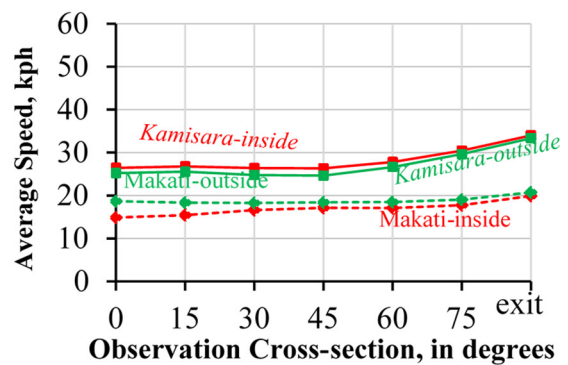

NWA Makati-inside lane (N=157)
NWA Makati-outside lane (N=151)

(d) Average vehicle speeds at different cross-sections

Fig. 7. Observed turning vehicle paths and speeds at the inside and outside DMT.

simultaneous “4-phase protected-only” for the subject double turn lane and the opposite single median-turn lane (Table 2). This encourages vehicles at the outside median-turning lane to follow the path provided by the median-turn lane markings due to the potential conflict with the opposite median-turning vehicles. Unlike in Makati intersection, approach-based signal phasing plan is implemented which provides vehicles at the outside lane with wider turning area which yield to wider variations in vehicle paths. In addition, due to the permitted right-turn on red on the opposite approach, the potential efficiency contribution of the outermost receiving lane was slightly deterred. Although this impact was limited when the approach was operated with DMT due to the low right-turn demand at the opposite approach. It is also important to mention that turning speed at Kamisara intersection was consistently and significantly higher than that of Makati intersection.

One of the important observations in Fig. 7 is the overlapping vehicle trajectories between the inside and outside DMT. To have better insights on this phenomenon, the distributions of vehicle trajectories at different cross-sections are presented in Table 4. It clearly shows that at Kamisara intersection, where median-turn markings are installed, there is no overlapping between vehicle trajectories except at the exit where a minor lane change was observed. However, at Makati intersection (no median-turn markings), an increasing overlapping ratio was observed reaching to 13.4% at the exit cross-section. These overlapping trajectories represent consecutive cross-maneuvering incidents that affected the headway of the succeeding vehicles in the queue and led to significant reduction in SFR up to 1570 pcphgpl (Fig. 6(b)) for the inside turning lane. Therefore, this unfavorable behavior of turning vehicles could be one of the major factors that resulted to low SFRs of double median-turn lanes at Makati intersection. It is expected that the installation of median-turn markings will guide drivers to be confined with their turning lane, which will limit the cross-maneuvering incidents.

It is important to mention that the applied phasing plan at Makati intersection is not suitable considering the high median-turning vehicle demand from both NWA and SEA and the relatively lower through vehicle demand. This led to long cycle length (194 s) and insufficient green ratios for median-turning movements (0.2 for NWA phase) which was reflected in low capacity of the median-turn lanes. By adopting a phasing plan similar to that of Jimbocho intersection (Table 2), which includes exclusive median-turn phases, cycle length can be reduced up to 180 s. Furthermore, higher green ratios can be assigned to the exclusive median-turn phases (estimated green ratio for median-turn phase from NWA and SEA is 0.3) which yields to an average of 47% increase in the capacity of inside and outside median turn lanes.

4.2. Safety assessment

Observed crossing and collision encounters for double median-turn lanes DMT as defined in Fig. 3, are analyzed by estimating PET and TTC. Regarding crossing encounters, PET only can be estimated. At the EA of Kamisara intersection, all observed encounters were identified as non-crossing encounters, which means there were no crossing or collision encounters. This indicates that the operation of DMT at Kamisara intersection is reasonably safe and free of serious conflict between the inside and outside lane vehicles. This is probably due to the full compliance of the turning vehicles to the median-turn lane markings that clearly delineated the path between the two median-turn lanes. In contrary, at Makati intersection there were 20 crossing and 7 collision encounters out of the 111 observed encounters between vehicles in the inside and outside turning lanes as shown in Fig. 8. This large percentage of encounters can be attributed to the absence of median-turn lane markings, which magnifies the unfavorable cross-maneuvering behavior of the turning vehicles. Fig. 8(a) shows that 19 (95%) of the observed

Table 4
Spatial distribution of vehicle paths at the inside and outside DMT.

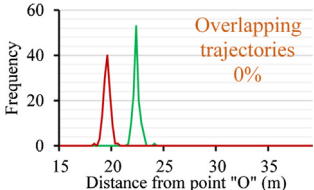
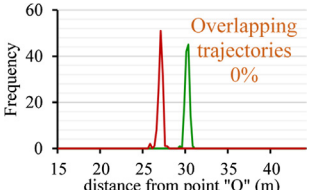
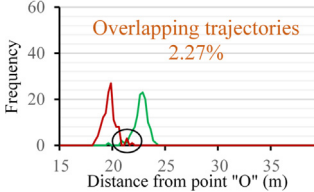
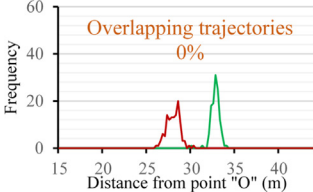
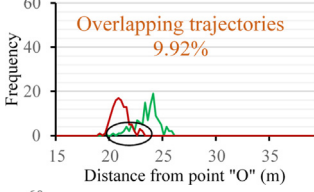
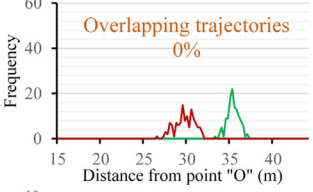
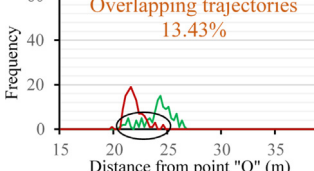
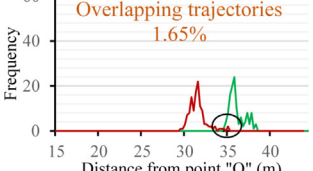
Cross-section line	Subject double median-turn lanes	
	Makati intersection, Makati, Philippines (N _{inside} = 157; N _{outside} = 207)	Kamisara intersection, Nagoya, Japan (N _{inside} = 121; N _{outside} = 151)
0°		
30°		
60°		
Exit		

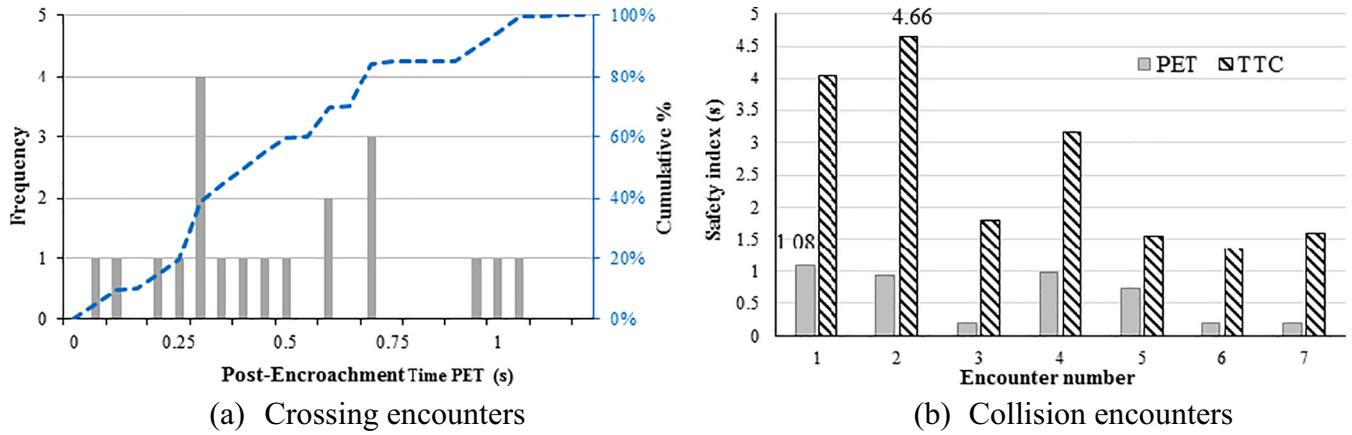

Fig. 8. Observed PET and TTC for crossing and collision encounter at Makati intersection.

crossing encounters have PETs < 1.0 s while 11 of them (55%) have PETs < 0.5 s. This clearly highlights the severity of these conflicts. Fig. 8 (b) shows the PET and TTC values for the observed 7 collision encounters. TTC values are very short up to 1.35 s and combined with very short PETs. This signifies that the turning vehicles at Makati intersection are in a severe conflict condition which are likely to lead to a rear-end collision. It is important to mention that the observed turning speeds at Makati intersection are lower than 20 kph which means that in

terms of collision severity, it has lower severity compared to potential collisions that may occur at Kamisara intersection which has turning speeds of around 30 kph (Fig. 7(d)).

The last collision encounter (number 7) presented in Fig. 8(b), is investigated as an example of these severe conflicts. Fig. 9 presents the detailed maneuver characteristics of both vehicles in the inside and outside turning lanes that were involved in the encounter number 7. Fig. 9(a) and (c) shows that the vehicle in the outside lane accelerated

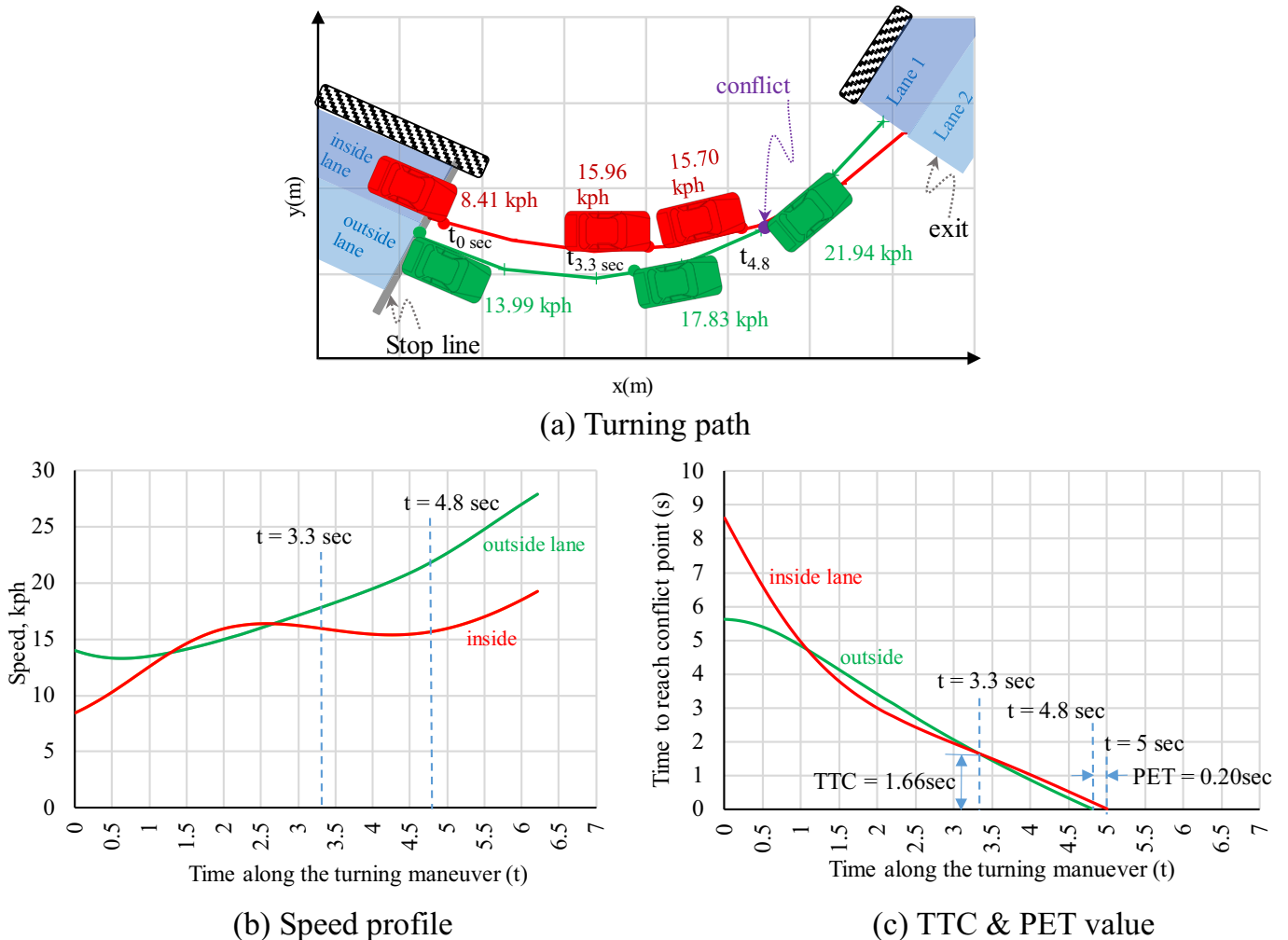

Fig. 9. Observed trajectories of conflicting turning vehicles in the collision encounter number 7 of Fig. 8 at Makati intersection, Philippines.

and suddenly moved to the inside lane which pushed the conflicting vehicle in the inside lane to slow down and move to the outside lane to avoid sharp speed reduction. This resulted in a situation that is very close to a crash with PET of 0.2 s. This indicates that the absence of clear boundaries between the double median-turning lanes may cause swerving behavior while turning and suggests that the utilization of median-turn lane markings through the intersection will guide drivers to avoid cross-maneuvering other vehicles and lane changing which will improve the safety performance.

5. Conclusion

This study assessed the impacts of the median-turn lane markings on the mobility and safety performance of median-turn lanes at signalized intersections in terms of SFR, average turning speed, and conflict severity. In the Philippines, an urban signalized intersection with double exclusive median-turn lanes without median-turn lane markings were assessed and compared to urban signalized intersections in Japan with median-turn lane markings. The results of the empirical analysis suggest that median-turn lane efficiency is highly influenced by several factors; (i) the availability of median-turn lane markings; (ii) number of available receiving lanes, and; (iii) the offset of the physical median island nosing. Specifically, the intersections in the Philippines were found out to have low efficiency and the turning vehicles had serious conflicts during the turning process due to the combined impact of the absence of median-turn lane markings and the cross-maneuvering behavior of the drivers. On the other hand, the intersection in Japan was found out to have high efficiency and safe turning process of the median-turning vehicles. However, considering the high average turning speed, the severity of a potential conflict or collision will be high. Moreover, the findings in the subject intersections in the Philippines and in Japan cannot generalize the results. Additional survey sites with median-turn lanes are necessary to be assessed in the future.

Acknowledgements

Authors are grateful to the International Association of Traffic and Safety Sciences (IATSS) for supporting this study through Project 1601A.

References

- [1] S. Brich, Positive guidance pavement markings for dual left-turn lanes, Technical Assistance Report for VTRC 1993, pp. 1–2.
- [2] JSTE, Japan Society of Transportation Engineers, Manual on Road Markings, 2012 (in Japanese).
- [3] DPWH, Department of Public Works and Highways of the Philippines, Road Signs and Pavement Markings Manual, 2012.
- [4] Japan International Cooperation Agency (JICA), National Economic Development Authority (NEDA), Roadmap for the transport infrastructure development for Metro Manila and its surrounding areas, Technical Report No. 2 2014, pp. (3)11–(3)13.
- [5] MMDA, Metropolitan Manila Development Authority, Metro Manila Accident Reporting and Analysis System (MMDA-MMRAS) Annual Report, 2016.
- [6] B. Persaud, L. Dzbik, Accident prediction models for freeways, Transportation Research Record No. 1401 1993, pp. 55–60.
- [7] M.A. Abdel-Aty, A.E. Radwan, Modeling traffic accident occurrence and involvement, *Accid. Anal. Prev.* 32 (2000) 633–642.
- [8] State Highway Administration, Maryland Department of Transportation, The Relationship Between Congestion Levels and Accidents, University of Maryland, 2003 5.
- [9] R.G. Atkins Jr., A.A. O'Leary, Transportation needs of the older driver, VTRC Report No. 93-R14, 1993.
- [10] F. Wei, et al., Left-turning vehicle trajectory modeling and guide line setting at the intersection, *Discret. Dyn. Nat. Soc.* 2014 (2014).
- [11] K. Fitzpatrick, et al., Effects of geometric and traffic variable on double left-turn operations, *Transp. Res. Rec. J. Transp. Res. Board* (2436) (2014) 32–42.
- [12] T. Sando, R. Moses, Influence of intersection geometrics on the operation of triple left-turn lanes, *J. Transp. Eng.* (2009) 253–259 (American Society of Civil Engineers).
- [13] A. Sobhani, et al., Calculating time-to-collision for analyzing right turning behavior at signalized intersections, *Australasian Transport Research Forum 2012 Proceedings*, 2012.
- [14] X. Wang, M. Abdel-Aty, Modeling left-turn crash occurrence at signalized intersections by conflicting patterns, *Accid. Anal. Prev.* 40 (2008) (2006) 76–88.
- [15] A. Laureshyn, et al., Evaluation of traffic safety, based on micro-level behavioral data: theoretical framework and first implementation, *Accid. Anal. Prev.* 42 (2010) (2010) 1637–1646.
- [16] K. Suzuki, H. Nakamura, TrafficAnalyzer – the integrated video image processing system for traffic flow analysis, *Proceedings of the 13th World Congress on Intelligent Transportation Systems*, 2006.
- [17] Transportation Research Board, Highway Capacity Manual, 6th edition, 2016.