



A Side-by-Side Comparison of Shaft Excavation locally in Qatar

John Brown

Parsons International Limited, Qatar
john.brown@parsons.com

Sunit Saurabh

Parsons International Limited, Qatar
sunit.saurabh@parsons.com

Ahmed Akslakhi

Public Works Authority (Ashghal), Qatar
aalslakhi@ashghal.gov.qa

Eisa Al-Mohannadi

Public Works Authority (Ashghal), Qatar
ealmohannadi@ashghal.gov.qa

Abstract

The city of Doha has grown and expanded rapidly in the last 20 years, but this growth has strained the city's infrastructure, including its aging sewerage system and treatment facilities. The Public Works Authority (Ashghal) has therefore launched several strategic schemes which involve shallow and deep sewer tunnels and a new sewage treatment works (STW) to serve Doha's growing population in the years to come. One such schemes is the C853/1 Wakrah-Wukair Drainage Network Branches (WWDNB), which includes more than 15 km of bored pipes between 400mm and 2.4m inner pipeline diameter, with more than 60 shafts ranging in depths from 10m to 47m. The geology in the Wukair area is made up of several distinct strata, typically ranging in material strength between 10 and 48MPa, and it is the range of strengths that decides the method of shaft excavation. This paper will provide a production comparison between two types of excavation methods adopted for the same depth shafts and geological conditions. In the first method, the Contractor adopted the more traditional method using an excavator with appropriate attachments to break the ground, where this progressed in a cyclical manner until the shaft base was reached. The second method incorporated a piling rig to drill a specific pattern of holes within the shaft envelope, which enabled a faster excavation cycle and allowed for time and cost savings as well as improved safety. This paper will assess both methods, why both were utilised, and the lessons learnt.

Keywords: Wakrah-Wukair; Shaft excavation; Piling rig; Comparison

1 Introduction

Wakrah-Wukair Drainage Network Branches project shafts have 2 main purposes, to act as a launch and/or a reception shaft for the micro-tunnel/pipe-jacking tunnel boring machines and also in their final state as an access point for monitoring and maintaining the sewage network.

The design process for the excavation of these shafts considers these purposes and incorporates the regional geology, available equipment, skills, safety, schedule and costs.

The shafts at WWDNB have been categorized as 2 types:

1. Local network, which is approximately 8m-30m in depth; these are primarily in local residential areas.
2. Main network shafts; these are 30m-48m in depth and are generally located closer to the final processing area, such as a sewage treatment plant.

2 Geology and Design Considerations

Several peer-reviewed geotechnical studies are available on the geology of the Wakrah-Wukair region of Qatar. This paper only provides a basic summary of the typical stratigraphic units encountered in the project area according to the Geotechnical Interpretative Report (2021) of the project, see Table 1 below.

Table 1: Project Geological Strata overview

Geological Strata	Unit thickness (m)	Material Strength (Avg. Uniaxial Compressive Strength of intact rock in MPa)	Brief description
Made ground & residual soils	0-2	-	Asphalt and gravel, poorly graded
Simsima Limestone	22-28	40	Limestone to dolomite weathered
Midra shale	5-7	15	Calcareous siltstone interbedded with limestone/dolomite
Rus Formation (Drilling didn't reach the bottom of this layer)	19-20	10	Limestone to Dolomite

To summarise the typical groundwater conditions that need to be considered, two main aquifers with a depth up to 50m, the first aquifer is located within the saturated zone of the Simsima Limestone and the second aquifer is in the Rus Formation located below the Midra shale. Both aquifers are hydraulically interconnected, meaning a dewatering design needed to be established during shaft construction to manage the high level of seepage, also possible karstic conditions needed to be considered.

2.1 Design Considerations

To establish the level of ground support required and to confirm the design, detailed ground investigation including borehole drillings, laboratory & in-situ tests along with the geophysical surveys such as the Multichannel Analysis of Surface Waves (MASW) and Electrical Resistivity Tomography (ERT) techniques were carried out for this project. MASW and ERT are the non-destructive site characterization techniques used for evaluating the stiffness of the ground for geotechnical engineering purposes. Details of correlation and matching between the results of surface geophysical methods, with available drilling boreholes or other subsurface data of the area, and the anomalies if any were highlighted and interpreted.

Later during the execution stage, an observational approach was adopted where the rock face mapping was performed by the geotechnical team for every 3m of unsupported depth reports in accordance with EN-ISO 14689-1 & 2 and BS-5930:1999 + A2:2010. Based on the mapping report, Q-value (NGI, 2015) was evaluated to interpret rock mass support category. For both shaft excavation methodologies, rock support was applied based on the Q value range recommended in the temporary works design for shaft excavation and support. Basis temporary lining type consists of a certain thickness of shotcrete with or without steel mesh along with additional measures if required.

The purpose of this analysis is extremely vital in terms of decision-making whether what approach is required to ascertain the choice of equipment and method of excavation based on the hardness of the

rock, which in-turn helps speculate the production rate of excavation. For analysis purpose of this research, we will be studying Shaft SH 8/3 and SH 8/1, which are both excavated with different methodologies, one with traditional method and the other with the aid of a piling rig. The geotechnical investigation and face mapping reports show that both the shafts are in the strata of calcareous, stable limestones with Q value ranges up to 4. This concludes the fact that we are required to deploy Jackhammer/Pile-rig excavators to break into the ground for reaching formation level.

3 Methodology

An analytical approach has been adopted to compare both methods of excavation, where two shaft SH 8/3 and SH 8/1 were selected for correlating the site parameters.

3.1 Methodology 1 – Shaft Excavation by Excavators only Shaft 8/3

Shaft SH 8/3 is a 47m deep shaft excavated in 11m diameter. Excavations have been done with different sized excavators depending on the depth. First 6 meters of excavation has been done with a standard boom wheeled excavator and breaker. Beyond this depth and down to 14 meters of depth, excavation proceeded with long boom and long reach tracked chain excavators and breaker, see Figure 1.

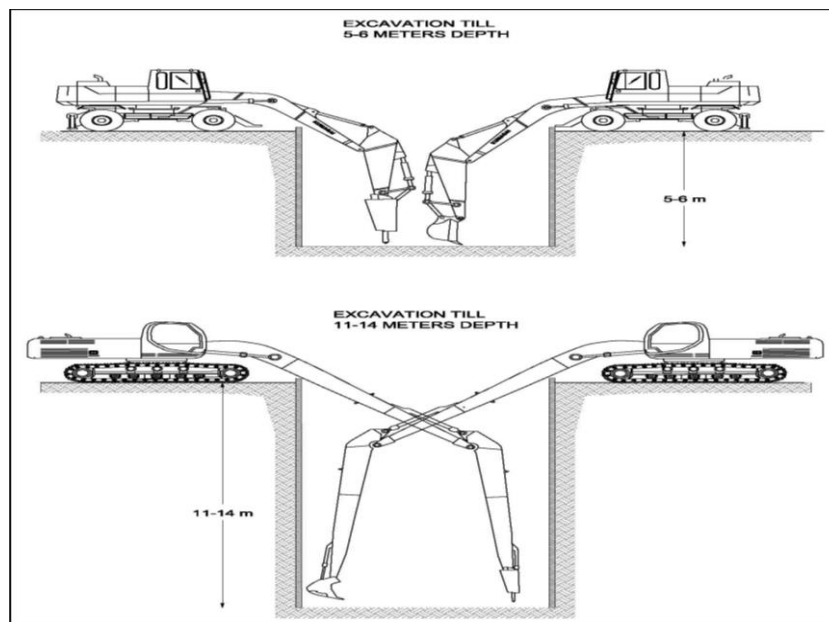

Fig. 1: Method 1 Initial Excavation of Shaft with Excavator and Breaker Attachments

Deeper than this and up to maximum depth of 50 meters, excavation then proceeded with mini/compact excavators (6-8 tons) which were lowered into the shaft while the excavated material was loaded into soil skips lowered and lifted by a mobile crane.

3.2 Methodology 2 – Excavation by a Combination of Excavators and a Piling Rig Shaft 8/1

Excavations for shaft 8/1 was carried out using the BAUER BG-11 H piling rig see Figure 2. The contractor used 2 piling rigs from Bauer: BG-28 (larger) and BG-11 H (smaller). The BAUER BG-11 H rig is able to drill down to maximum depth of 28 m, whereas the bigger rig BAUER BG-28 is able to reach the maximum depth of shafts on WWDNB Project.

The BAUER BG-11 H piling rig first drilled uncased bores within the shaft perimeter spaced (outside diameter to outside diameter) 50 cm in a grid configuration see Figure 3, then in each marked out bore location, drilled down to final depth of the shaft. The piling rig partly removed the ground spoil from the bore, leaving as much spoil inside the bore, yet not so much to maintain the balance of torque

power of the rig. Upon finishing the bore, the spoil that was brought out of the excavated hole was pushed back into the hole. This method was repeated for each bore.



Fig. 2a: Photograph of BAUER BG-11 Piling Rig in Action

The Progressive Auger BAUER SBF-P2 and Rock drilling bucket BAUER KBF-P (with progressive bottom gate) were used as cutting tools. SBF-P2 and KBF-P are recommended in uncased bores or for the bigger diameters. Mainly it suited for strong rock (50-100MPa).

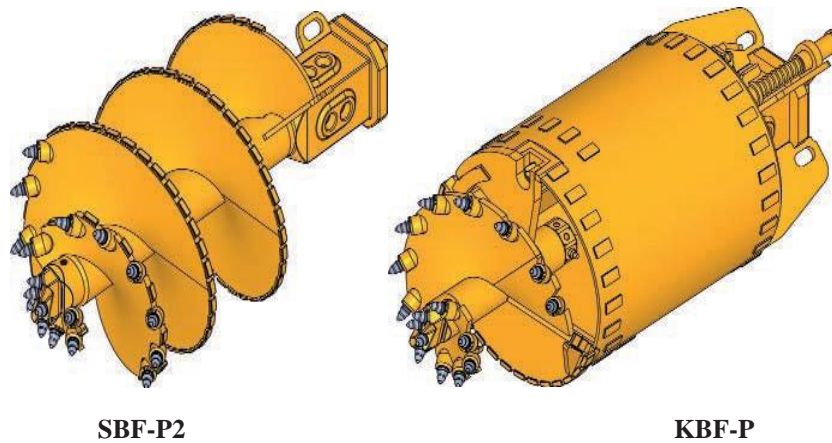

SBF-P2

KBF-P

Fig. 2 b: Photograph of BAUER SBF-P2 & KBF-P

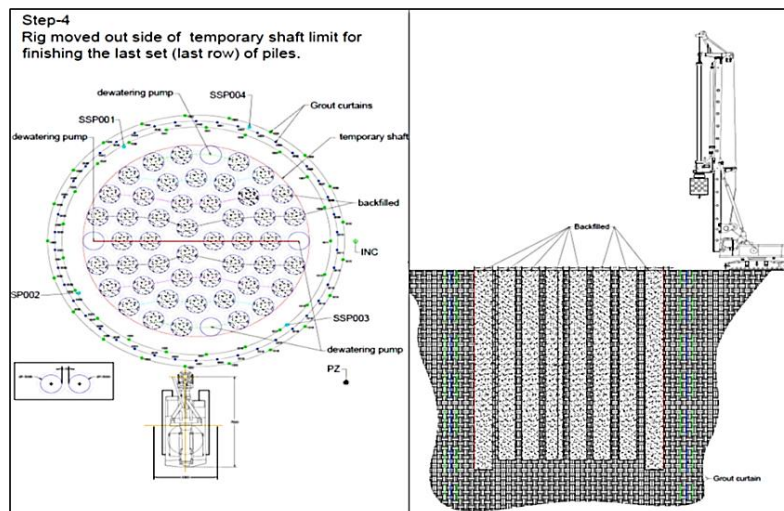

Fig. 3: Piling Rig Excavation Layout Plan and Section

When all the holes within the perimeter of the shaft have been drilled, the next stage is similar to method 1, using an excavator with a bucket to remove the broken spoil see Figure 4, making the excavation process significantly quicker as the material within the shaft has now been significantly broken up, the same methods of using shotcrete as shaft support was still used.

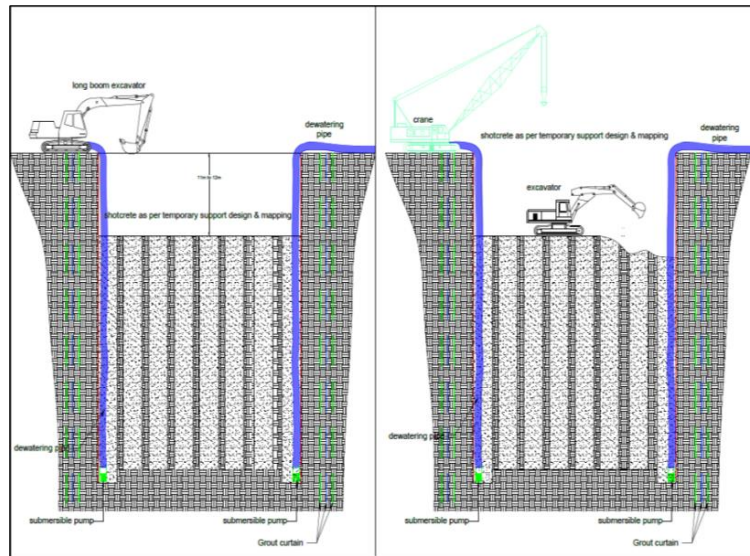

Fig. 4: Excavation of Shaft after Piling Rig has Drilled the Holes

4 Comparison of Both Shaft Excavation Methodologies

Table 2 shows a side-by-side comparison using Method 1 and Method 2 to excavate the shafts; these results are typical across the project.

Table 2: Side-by-side comparison of both methods

Detail/Type	Excavation by Excavator Only Method 01	Excavation Aided by Piling Rig Method 02
	SH 8/3	SH 8/1
Shaft Excavation Diameter	11m	11m
Shaft Depth	47m	47
Total volume to be excavated in (m ³)	~4470 m ³	~4470 m ³
Start of excavation (actual)	13 th Mar 2022	14 th Sep 2022
End of excavation (actual)	19 th Oct 2022	21 st Dec 2022
Total no. of days from start till end	220 days	98 Days
Total lifts for Shafts Lining	12 Lifts (every 4m of depth = 47/4)	12 Lifts (every 4m of depth = 47/4)
Total number of days for each Lift lining	02 days	02 days
Total number of days for full depth for lining work	24±5 (12x2)	24±5 (12x2)
Total days actual excavation	196 days (220-24)	74 Days (98-24)
Production rate (total volume/total day actual excavation) m ³ /day	~23 m ³ /day (4467 m ³ /190 days)	~60 m ³ /day (4470 m ³ /74 days)
Limitations	Not suitable with areas of existing utilities thus requires extensive existing utility survey	<ol style="list-style-type: none"> 1. More breakdown since machines working with impact/jackhammers 2. Changing jackhammer to bucket and bucket to jackhammer in the excavators cause extra time slippage

Equipment type used	<ol style="list-style-type: none"> 1. Excavator 30T or 20T (Tire or Chain) 2. Excavator long mast Arm 18m 3. Crane 100T or 150T 	<ol style="list-style-type: none"> 1. Piling rig 2. Excavator 30T or 20T (tire or chain) 3. Excavator long mast Arm 18m 4. Crane 100T or 150T
----------------------------	--	---

5 Conclusion and Lessons Learned

Data shown in above Table 2 clearly indicates the following results:

1. Productivity rate in method 02 is recorded nearly ~ 2.6 times greater than that of the conventional method.
2. If the groundwater and geological conditions are similar, it is recommended to adopt method 2 for faster progress of the construction.
3. Probability of breakdowns of machines/equipment in method 01 is more since it required consistent effort of jack-hammer excavators for rock breaking, causing repetitive wear and tear.
4. Quality process using both methodologies was observed the same.
5. Although the risk/hazards are increased in method 2 due to deployment of additional resources, this is still recommended to adopt it, considering the higher productivity rate.
6. Since the productivity is substantially increased in method 2, that saved the considerable duration of the construction and therefore it leads to a cost effective solution.

6 Acknowledgements

The authors are grateful to the Public Works Authority, Qatar (ASHGHAL) for giving the opportunity to publish this paper. Token of thanks to the management of Parsons International Ltd. for the necessary support and guidance and as well as the contractor's management for inputs during the paperwork.

References

- British Standards Institution. (2013) *Eurocode 7: Geotechnical Design - Part 1: General rules*. BS EN 1997-1:2004+A1: 2013.
- Geotechnical Interpretative Report (2021). Doc. no. C853/1-QTC-GEO-RPT-00008 Rev.2, Wakrah and Wukair Drainage Network Branches –C853/1.
- Norwegian Geotechnical Institute. (2015) *Using the Q-system: Rock Mass Classification and Support Design*. s.l.: NGI, 2015.

Cite as: Brown J., Saurabh S., Alslakhi A. & Al-Mohannadi E., "A Side-by-Side Comparison of Shaft Excavation locally in Qatar", *The 2nd International Conference on Civil Infrastructure and Construction (CIC 2023)*, Doha, Qatar, 5-8 February 2023, DOI: <https://doi.org/10.29117/cic.2023.0024>